

**For hydraulic car-parking ports and material lifting platforms**

The Blain car parking platform valve can be used in car parking applications where the platform needs to be raised above the ground to accommodate another car below the port. Alternatively this valve is also ideal for lifting material, cargo and suitable for dumb-waiters and goods lifts. The valve offers single up speed and adjustable down speed.

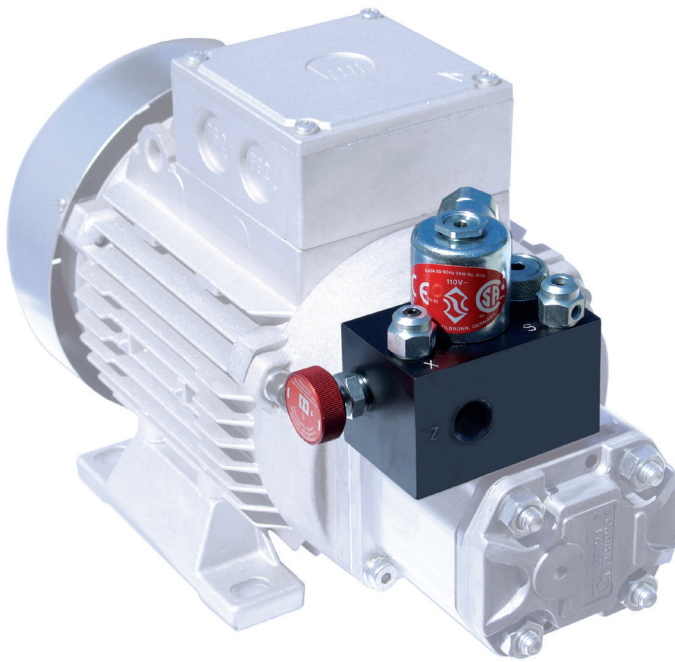

- Flow Range:** 1-24 l/min (0.3 – 6.3 US gpm)
- Oil Viscosity:** 25-60 cSt. at 40°C (104°F)
- Coils AC:** 24 V/1.8 A, 42 V/1.0 A, 110 V/0.5 A, 230 V/0.18 A, 50/60 Hz
- Coils DC:** 12 V/2.1 A, 24 V/1.1 A, 42 V/0.6 A, 80 V/0.3 A, 125 V/0.25 A, 196 V/0.14 A
- Ports:** P Pump, Z Cylinder and T Tank
- Pressure Range:** 3-130 bar (44-1885 psi)
- Burst Pressure:** 600 bar (8702 psi)
- Insulation Class, AC and DC:** IP 68

Check valve, pressure relief valve and manual lowering are standard options which are integrated in the GV valve. Additionally a shut off valve is also provided to shut the flow of oil from the pump to cylinder and vice-versa. The valve offers a standard 3/8" cylinder and tank connection, whereas the pump connection is available in sizes 1/4", 3/8" and 1/2".

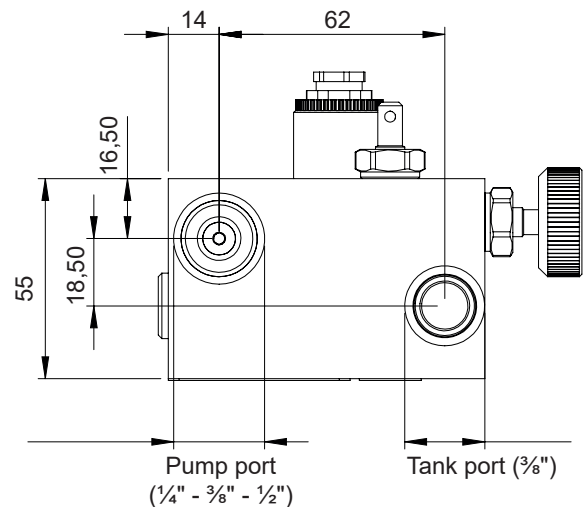
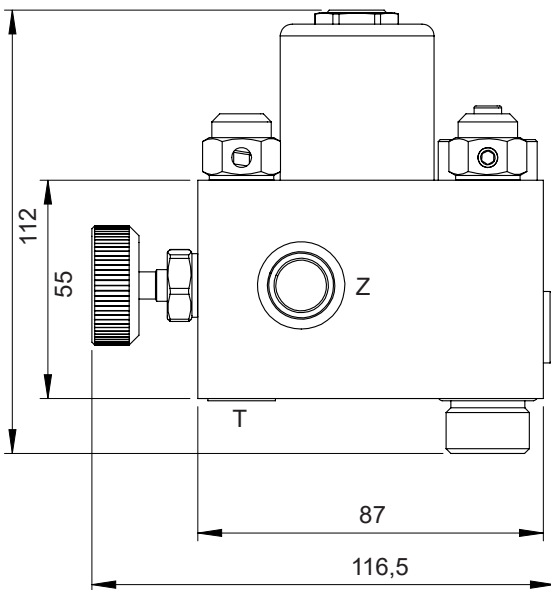

Blain Hydraulics GmbH Tel. +49 7131 28210  
 Pfaffenstrasse 1 Fax +49 7131 282199  
 74078 Heilbronn www.blain.de  
 Germany info@blain.de



GmbH

Designer and Manufacturer of the highest quality control valves & safety components for hydraulic elevators



### Electrical Sequence

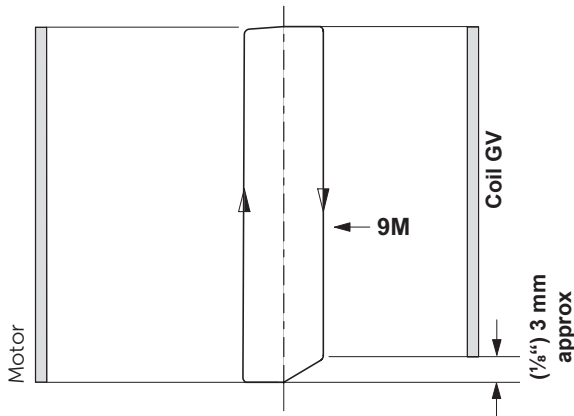

### Hydraulic Circuit

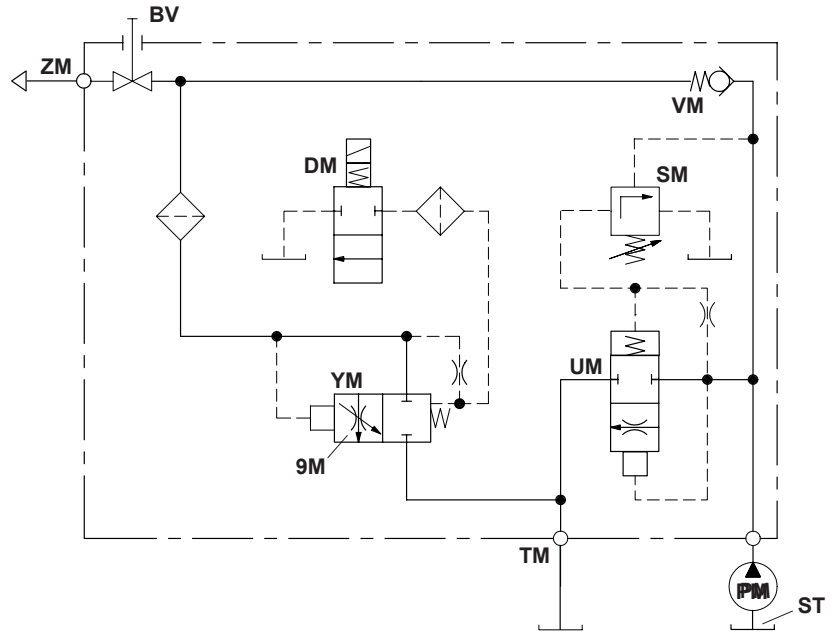

- DM** Solenoid Down
- 9M** Down Speed Adjustment
- SM** Pressure Relief Valve Adjustment
- VM** Check Valve

- BV** Shut Off Valve
- ST** Suction Tube
- ZM** Cylinder Connection
- TM** Return Connection

- UM** Pilot Operated Relief Valve
- YM** Pilot Operated Down Valve
- PM** Pump Motor

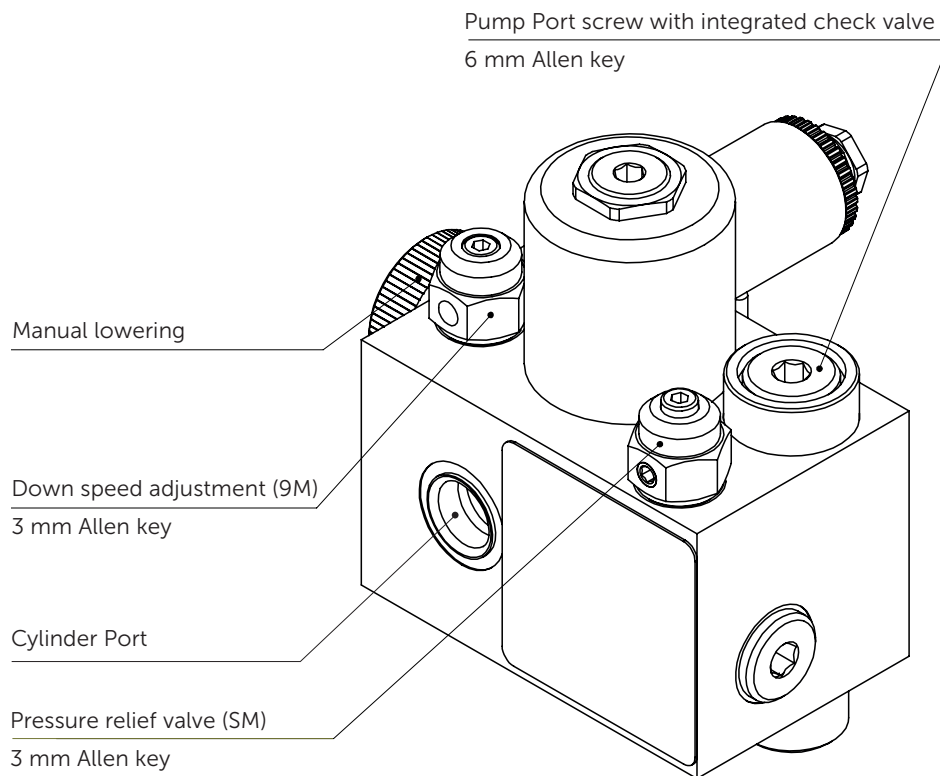

### GV Adjustments

**Up Speed** is determined by the pump output and the effective diameter of the cylinder system.

**SM Relief Valve.** 'In' (clockwise) produces a higher, 'out' (c-clockwise) a lower maximum pressure setting.

**9M Down Speed.** When coil **DM** is energized, the car will travel downwards at a speed according to the setting of adjustment **9M**, (3 mm Allen key). Turning 'in' (clockwise) provides a slower, turning 'out' (c-clockwise), a faster down speed.

### While ordering

Please specify pump flow, coil voltage and maximum operating pressure.