



Instruction Manual - L10 Pressure Lock Valve (UCM/A3 Valve)



Certified by TÜV SÜD Germany



1/2"



3/4"



1 1/2"



2"



2 1/2"

Warning: Only qualified personnel should adjust or service valves. Unauthorised manipulation may result in injury, loss of life or damage to equipment.



Prior to servicing internal parts, ensure that the electrical power is switched off, ball valve is closed and residual pressure in the valve is reduced to zero. Very high pressure spikes could result in deformation and oil splashing, this could cause serious injuries.

L10 Description: The L10 Pressure Lock Valve is a solenoid operated check valve designed for hydraulic elevators and includes a self closing manual lowering valve. Its purpose is to allow free flow of oil from the pump unit to the cylinder for up travel and to prevent flow in the reverse direction from the cylinder to pump until an electrical signal is given to the coil. The L10 can be mounted in any position without causing any operational problems.

Installed in the main cylinder line directly adjacent to the main elevator control valve, the L10 can be employed as a safety back up valve to the down system of the main control valve to prevent unwanted down movement of the elevator should an electrical or mechanical malfunction occur in the main control valve (UCM case).

Another application of the L10 is to reduce the amount of bounce in a hydraulic elevator system due to the compressibility factor of oil between the cylinder and the control valve, by mounting the L10 directly onto the cylinder connection.

A Slack Rope Valve LK for roped elevators (e.g. 2:1 indirect transmission) is optional. It prevents the slack rope condition caused by the lowering of the ram when the car is suspended in the safeties or resting on the buffers.

Technical Data:		1/2" L10	3/4" L10	1 1/2" L10	2" L10	2 1/2" L10
Flow Range:	l/min	80	125	400	800	1400
Pressure Range:	bar	10-100	10-100	10-100	10-80	10-70
Permitted pressure (according AR 2014/33/EU):	bar	10-100	10-100	10-59 (75*)	12-59	10-59
Burst Pressure:	bar	500	500	500	450	365
Tank Connection for LH	TN	1/4"	1/4"	1/2"	1/2"	1/2"
Weight:	kg	0,8	1,4	2,5	4,2	7,0
PB Cylinder pressure port:	G	1/4"	1/4"	1/4"	1/4"	1/4"

* optional pressure with special parts

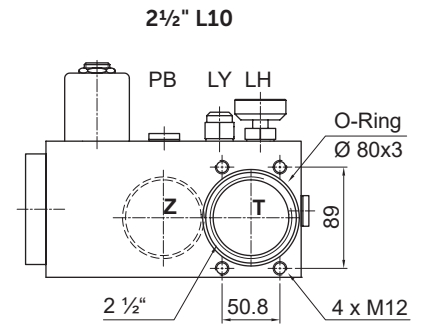
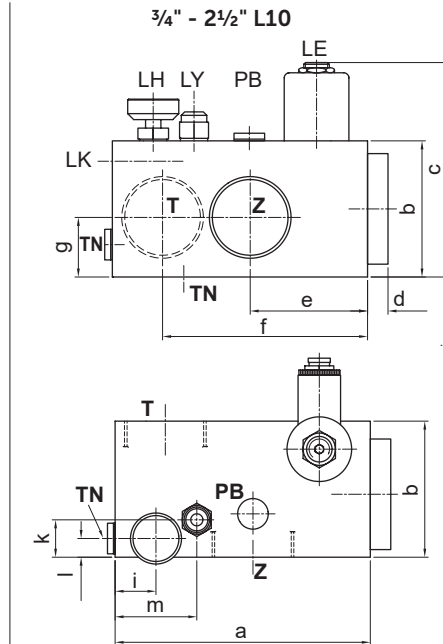
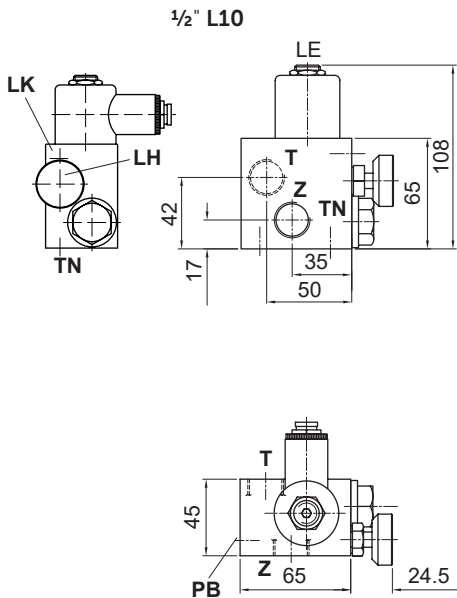

L10	3/4"	1 1/2"	2"	2 1/2"
a	110	150	175	210
b	65	80	100	120
c	108	134	154	174
d	8	12	12	16
e	60	69	75	89
f	92	120	136	160
g	31	35	45	55

possible AC coil voltages: 24 V/1.8 A; 42 V/1.0 A; 110 V/0.43 A; 230 V/0.18 A; 50/60 Hz

possible DC coil voltages: 12 V/2.0 A; 24 V/1.1 A; 42 V/0.5 A; 48 V/0.6 A; 80 V/0.3 A; 110 V/0.25A; 196 V/0.14 A

T→Z Free Flow. Solenoid LE not energized.

Z→T Flow only when Solenoid LE energized.

Attention: For manual lowering connect port TN with tank.

Blain Hydraulics GmbH
 Pfaffenstrasse 1
 74078 Heilbronn
 Germany
 Tel. +49 7131 28210
 Fax +49 7131 282199
 www.blain.de
 info@blain.de



GmbH

Designer and Manufacturer of the highest quality control valves & safety components for hydraulic elevators



Rest Position: When L10 is at stand-by, the coil **LE** is de-energized and the main flow guide **LV** closed, preventing flow from cylinder to tank.

Up Travel: During up travel with the pump running, oil flows through port **T**, through the flow guide **LV** and out through port **Z** to the main cylinder. Coil **LE** is not energized.

Down Travel: For the car to have a down travel, the L10 should be energized approximately 0.5s earlier than the main control valve (e.g. EV100). This enables the oil to escape from the pilot chamber and allows the main piston **LV** to open. Else, the pressure between the L10 and the control valve connecting line drops considerably and to make the elevator operational, the connecting line needs to be re-pressurized again. This can be done by starting the elevator for a short time in the up direction or by pumping oil using a hand pump. Re-pressurizing may also be needed if the main control valve has an internal leakage. Opening of the **LV** allows the flow of oil from the cylinder to the tank (from **Z** to **T**) via the L10 and the main control valve.

The coil **LE** on the L10 valve is de-energized after the down coil of the main control valve (e.g. coil D of EV100). In this way, the piston **LV** in L10 and the down piston **X** in the main control valve close completely.

Pressure drop: The pressure loss of the L10 valve depends on the size of the valve and the flow rate. The size and type of connectors used also influence the pressure losses. The pressure loss of the L10 valve should be taken into account while the main control valves empty car pressure is calculated.

Emergency down: The emergency manual lowering **LH** on the L10 is to be operated to bring the car down in emergency. The down speed of the car is determined by the setting of **LY**. As the **LH** is open, oil from the cylinder flows back to the tank through a return tank-line attached to the tank port **TN**. The return tank-line should not be smaller in size than the tank port **TN**, else the emergency manual lowering may not function properly.

The slack rope valve **LK** prevents the sinking of the RAM when the manual lowering **LH** is operated in a 2:1 roped elevator to prevent a tangled rope condition.

Air-bleed: After connecting the L10 valve or right after servicing the L10 valve needs to air-bleeded to ensure its functionality. It is sufficient to operate the emergency lowering valve or loosening the coil tube slightly until oil is visible and tightening it again.

Adjustments

Manual Down Speed **LY** (3/4", 1 1/2", 2" and 2 1/2" valves): 'In' (clockwise) provides a slower, 'out' a faster down lowering speed.

Slack Rope Valve **LK:** The **LK** is adjusted with a 3 mm Allen key by turning the screw **LK** 'in' for higher pressure and 'out' for lower pressure. With **LK** turned all the way 'in', then half a turn back out, the unloaded car should descend when the **LE** coil is energized. Should the car not descend, **LK** must turned out until the car just begins to descend, then turned out a further half turn to ensure that with cold oil, the car can be lowered as required.

Functional test

In order to check the functionality of the L10 pressure lock valve, the coil **LE** can be de-energized during down travel. Alternatively the L10 can also be tested by unscrewing the retaining nut **MM** and manually lifting the coil **M**.

Caution! Once the coil **M** is removed from the coil tube **DR**, the energized coil will begin to overheat after about 10 seconds, holding it out longer may result in burning of coil.

The test may result in pressure drop in the connecting line between L10 and the control valve. In order to make the elevator operational, the connecting line needs to be pressurized again. This can be done by using the handpump to move the cabin over a small distance in up direction. Pressurising the line might also be necessary in cases where the pressure loss between the L10 and control valve is high for e.g. due to internal leakage.

Filter FH (optional)

Severely contaminated oil can lead to internal leakage in the area of the emergency lowering **LH** or **LY**. This can be prevented by installing the **L10** with the optional filter **FH**. Retrofitting the filter is not possible in the older L10 valves.

Status of lift	Power supply to coil of L10
Up travel and releveling	power off
Down travel and releveling	power on
Stop with door closed	power can be switched off to save standby power
Unintended up travel with open doors	motor off once the movement sensor gets triggered
Unintended down travel with open door	power off once the movement sensor gets triggered
Emergency lowering	power on
Emergency manual lowering	manual actuation
Hand pump operation	power off

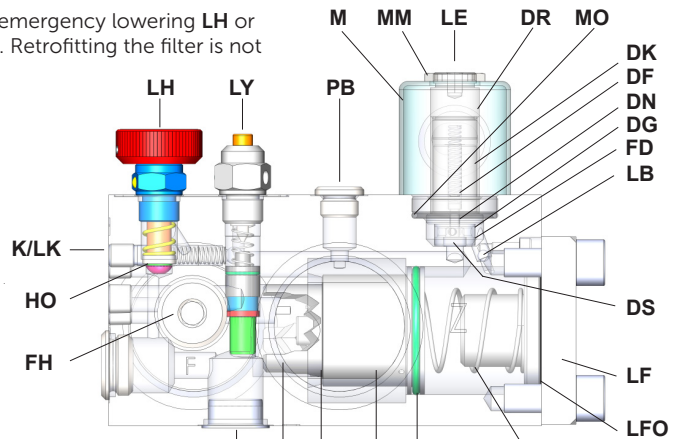

L10 1 1/2" - 2 1/2"
Do not reduce G 1/2" -
Use 1/2" tubing
(18 x 1,5)

Hydraulic Circuit

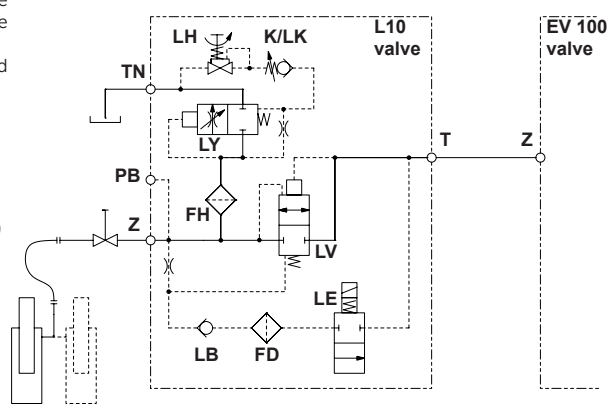

No.	Parts List
LF	Flange
LFO	O-Ring- Flange
LB	Ball
LVF	Spring - Flow Guide
LFG	Flow Guide
LVO	Seal - Flow Guide
LVB	Body - Flow Guide
LUO	O-Ring - Flow Guide
LH	Manual Down - Self Closing
LY	Manual Down Speed Adjuster
HO	Seal - Manual Low. (5.28x1.78)
MM	Nut
M	Coil (indicate voltage)
DR	Solenoid - Tube
MO	O-Ring
DF	Spring
DN	Needle
DK	Core
DG	Seat Housing (with screen)
FD	Filter
DS	Seat

Maintenance
Maintenance of the L10 is not necessary. Inspection of internal leakage should be done in regular intervals, at least once a year. If internal leakage has been detected, check the parts **DN**, **DS** and **FD** of the Solenoid **LE** first. Then inspect the O-rings of **LV**, **LY** and **LH**. The pressure of the valve has to be released before. The filter **FH** should be checked and cleaned during maintenance.

Control Elements
LV Check Valve
LH Manual Lowering
LK Slack Rope Valve (option)
LE Solenoid
PB Pressure Gauge (cylinder pressure)
LY Manual Down Speed Adjust. (not with 1/2" L10)

Connections
T Control Valve Connection
Z Cylinder Side Connection
TN Tank Return Line