

User Manual – L20 Pressure Lock Valve (UCM/A3 Valve)

Certified by Lift Instituut

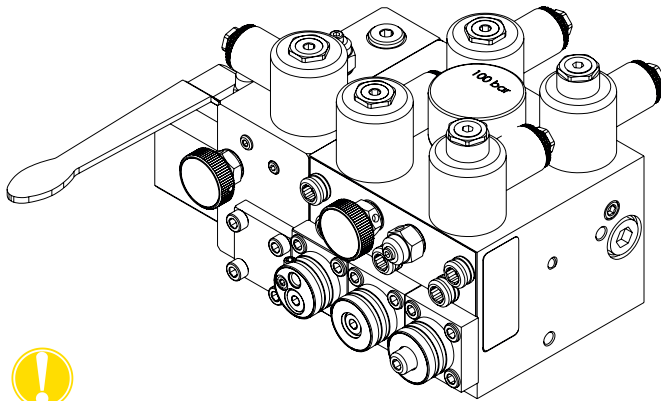

EN ISO 9001



Warning: Only qualified personnel should adjust or service valves. Unauthorized manipulation may result in injury, loss of life or damage to equipment. Prior to servicing internal parts, ensure that the electrical power is switched off, ball valve is closed and residual pressure in the valve is reduced to zero. Very high pressure spikes could result in deformation and oil splashing, this could cause serious injuries.

L20 Description: The **L20** Pressure Lock Valve is a solenoid operated check valve designed for hydraulic elevators and includes a self-closing manual lowering valve. Its purpose is to allow free flow of oil from the pump unit to the cylinder for upward travel and to prevent flow in the reverse direction from the cylinder to pump until an electrical signal is given to its solenoid.

The **L20** is to be directly mounted on a Blain EV 3/4" valve at the cylinder port without the need of any adapters. It can be either used as a standalone safety valve by docking on an existing Blain EV valve with separate tank line (for modernizing old installations) or can be used as an integrated safety valve together with Blain's EVL valve without the need of separate tank connection.

Installed in the main cylinder line directly integrated with the main elevator control valve, the **L20** can be employed as a safety back up valve to the down system of the main control valve to prevent unwanted down movement of the elevator should an electrical or mechanical malfunction occur in the main control valve (UCM case).

A Slack Rope Valve **LK** for roped elevators (e.g. 2:1 indirect transmission) is optional. It prevents the slack rope condition caused by the lowering of the ram when the car is suspended in the safeties or resting on the buffers.

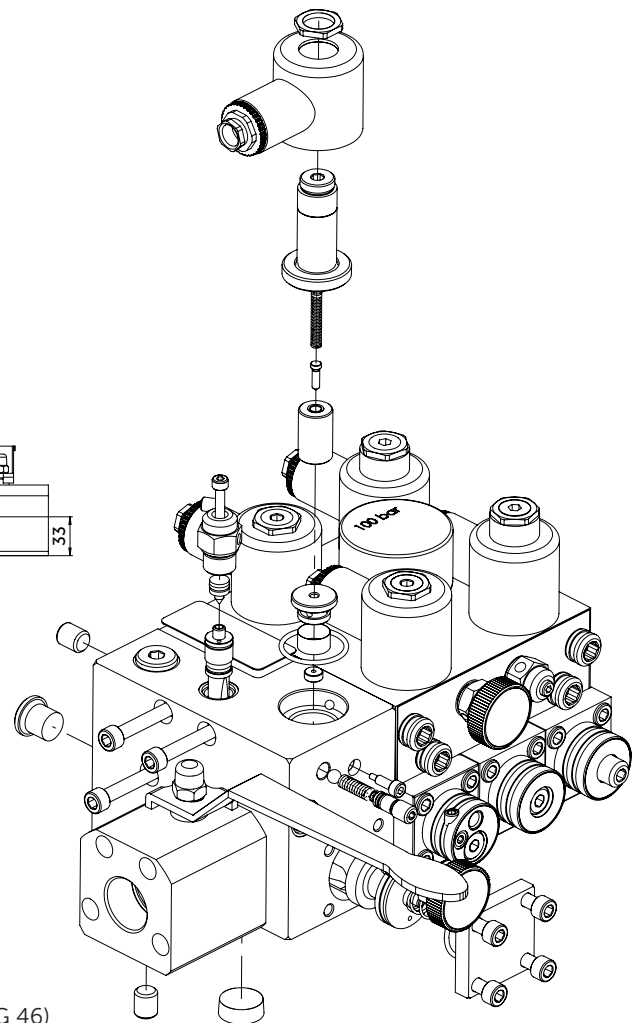
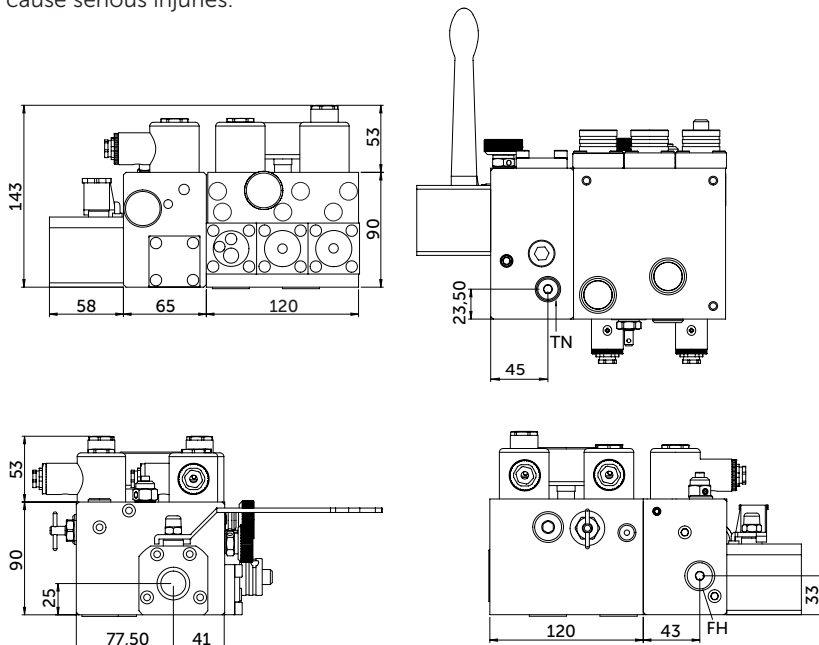

Attention: For manual lowering connect port **TN** with the tank. The second **TN** must be closed with a screw plug.

T→Z Free Flow. Solenoid **LE** not energized.
Z→T Flow only when Solenoid **LE** energized.

**UK
CA**

certificate No. UK17-400-1002-262-02 rev. 1

Technical Data:

		L20
Flow Range max.:	l/min	10-125
Operating Pressure min./max.:	bar	8-100
Burst Pressure:	bar	>500
Tank Connection for LH	TN	1/4"
Weight:	kg	2 kg
Operating viscosity range: 20 cSt. to 200 cSt. (~15°C to 56°C for ISO VG 46)		
Max. Oil Temperature: 70°C		
Solenoids ~: 24 V/1.8 A, 42 V/1.0 A, 110 V/0.43 A, 230 V/0.18 A, 50/60 Hz		
Solenoids =: 12 V/2.0 A, 24 V/1.1 A, 42 V/0.5 A, 48 V/0.6 A, 80 V/0.3 A, 110 V/0.25 A, 196 V/0.14 A		
Insulation Class, (~/=): IP 68		

Blain Hydraulics GmbH Tel. +49 7131 28210
 Pfaffenstrasse 1 Fax +49 7131 282199
 74078 Heilbronn www.blain.de
 Germany info@blain.de



GmbH

Designer and Manufacturer of the highest quality control valves & safety components for hydraulic elevators



Rest Position: When L20 is at stand-by, the solenoid LE de-energized and the main flow guide LV closed, preventing flow from cylinder to tank.

Up Travel: During up travel with the pump running, oil flows through port T, through the flow guide LV and out through port Z to the main cylinder. Solenoid LE is not energized.

Down Travel: For the car to have a down travel, the L20 should be energized approximately 0.5s earlier than the main control valve (e.g. EV100). This enables the oil to escape from the pilot chamber and allows the main piston LV to open. Re-presurizing may also be needed if the main control valve has an internal leakage. Opening of the LV allows the flow of oil from the cylinder to the tank (from Z to T) via the L20 and the main control valve. The solenoid LE on the L20 valve is de-energized after the down solenoid of the main control valve (e.g. solenoid D of EV100). In this way, the piston LV in L20 and the down piston X in the main control valve closes completely.

Pressure drop: The pressure loss of the L20 valve depends on the flow rate.

Emergency down: The emergency manual lowering LH on the L20 is to be operated to bring the car down in emergency. The down speed of the car is determined by the setting of LY. As the LH is open, oil from the cylinder flows back to the tank through a return tank-line attached to the tank port TN1 or TN2 (if case of external tank connections) or directly to the main control valve (e.g. EV100) in case of integrated option. The return tank-line should not be smaller in size than the tank port TN1 or TN2, else the emergency manual lowering may not function properly. The slack rope valve LK prevents the sinking of the RAM when the manual lowering LH is operated in a 2:1 roped elevator to prevent a tangled rope.

Air-bleed: After connecting the L20 valve or right after servicing the L20 valve needs to air-bleeded to ensure its functionality. It sufficient to operate the emergency lowering valve or loosening the solenoid tube slightly until oil is visible and tightening it again.

Adjustments

Manual Down Speed LY: 'In' (clockwise) provides a slower, 'out' a faster down lowering speed.

Slack Rope Valve LK: The LK is adjusted with a 3 mm Allan Key by turning the screw LK 'in' for higher pressure and 'out' for lower pressure. With LK turned all the way 'in', then half a turn back out, the unloaded car should descend. Should the car not descend, LK must be backed off until the car just begins to descend, then backed off a further half turn to ensure that with cold oil, the car can be lowered as required.

Functional test

In order to check the functionality of the L20 pressure lock valve, the solenoid LE can be de-energized during down travel. Alternatively the L20 can also be tested by unscrewing the retaining nut MM and manually lifting the solenoid coil M.

Caution! Once the coil M is removed from the solenoid tube DR, the energized coil will begin to overheat after about 10 seconds, holding it out longer may result in burning of solenoid coil.

Filter FH (optional)

Heavily contaminated oil can cause internal leakage in the area of the emergency lowering LH. This is prevented by installing the optional filter FH. Retrofitting is not possible with older L20 valves.

Status of lift	Power supply to coil of L20
Up travel and releveling	power off
Down travel and releveling	power on
Stop with door closed	power can be switched off to save standby power
Unintended up travel with open doors	motor off once the movement sensor gets triggered
Unintended down travel with open door	power off once the movement sensor gets triggered
Emergency lowering	power on
Emergency manual lowering	manual actuation
Hand pump operation	power off

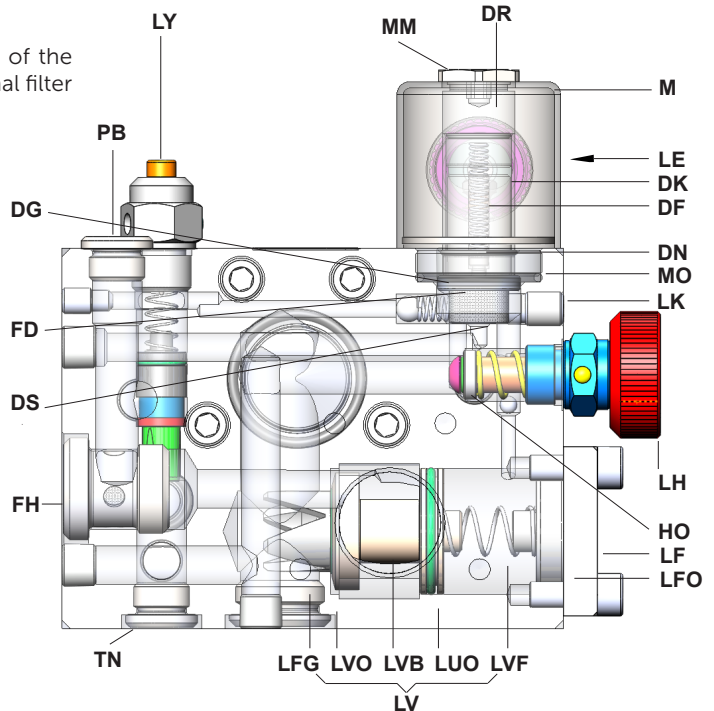

No.	Parts List
LF	Flange
LFO	O-Ring - Flange
LB	Ball - Solenoid (Check Valve)
LVF	Spring - Flow Guide
LFG	Flow Guide
LVO	Seal - Flow Guide
LVB	Body - Flow Guide
LUO	O-Ring - Flow Guide
LH	Manual Down - Self Closing
LY	Manual Down Speed Adjuster
HO	Seal - Manual Low. (5.28x1.78)
MM	Nut Solenoid
M	Coil Solenoid (indicate voltage)
DR	Tube - Solenoid
MO	O-Ring Solenoid
DF	Spring Solenoid
DN	Needle Solenoid
DK	Core Solenoid
DG	Seat Housing (with screen)
FD	Filter Solenoid
DS	Seat Solenoid
FH	Filter Manual Down

Maintenance

Maintenance of the L20 is not necessary. Inspection of internal leakage should be done in regular intervals, at least once a year. If internal leakage has been detected, check the parts DN, DS and FD of the Solenoid LE first. Then inspect the O-rings of LV, LY and LH. The pressure of the valve has to be released before. The FH filter should be regularly cleaned during maintenance.

Control Elements

- LV Check Valve
- LH Manual Lowering
- LK Slack Rope Valve (option)
- LE Solenoid
- PB Pressure Gauge (cylinder pressure)
- LY Manual Down Speed adjustment

Connections

- T Control Valve Connection
- Z Cylinder Side Connection
- TN Tank Return Line

