

The MRL-H has been designed for servicing and rescuing operations of machine roomless (MRL) hydraulic elevators remotely by having easy outside access, without needing to be in the pit. Many functional valves such as an adjustable self-closing manual lowering valve, hand pump, slack rope valve, pressure relief valve, ball valve as well as a manometer have been added to a compact body. MRL-H can be located up to 6 metre (19 feet) away and 5 metre (16 feet) high from the main power unit to a convenient location for easy access. MRL-H can be optionally delivered with pipes and necessary accessories upon request.

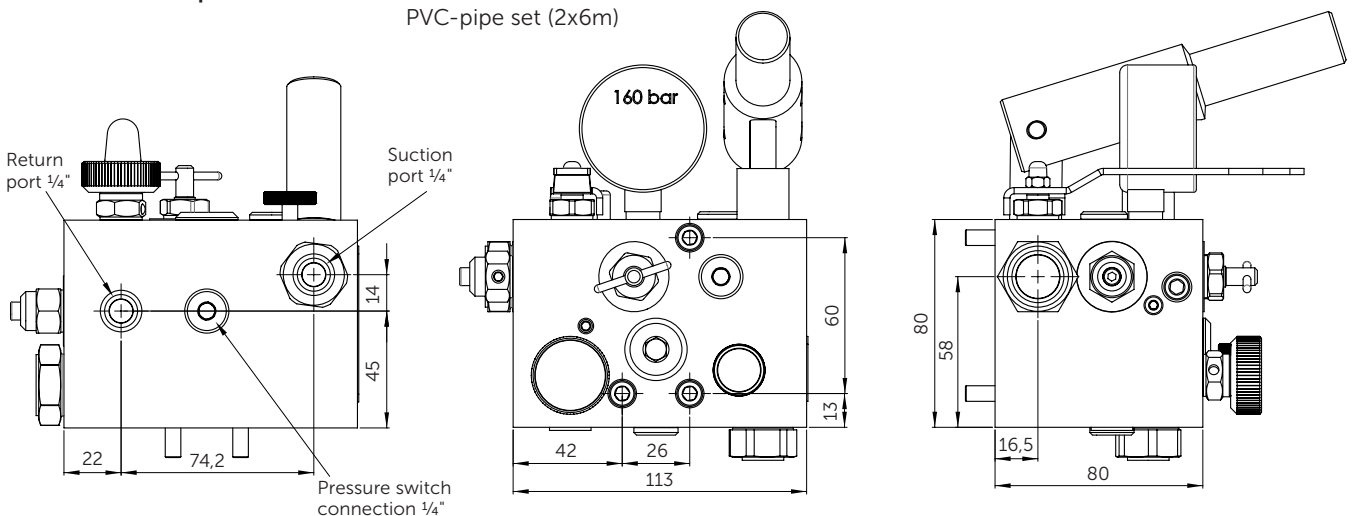

Output port:	1/2" BSP	Pressure switch port (2 times):	1/4" BSP
Suction port:	1/4" BSP	Pressure range:	0-100 bar (0-1450 psi)
Return port:	1/4" BSP	Oil Viscosity:	(25-60) cSt. bei 40°C (15-35 cSt. at 120°F)
max. suction height:	5 m (with PVC-pipe inside-Ø6 mm); check valve recommended at suction point for pipe length longer than 1 m		
Options:	check valve PVC-pipe set (2x6m)		



Blain Hydraulics GmbH
 Pfaffenstrasse 1
 74078 Heilbronn
 Germany

Tel. +49 7131 28210
 Fax +49 7131 282199
 www.blain.de
 info@blain.de



GmbH

Designer and Manufacturer of the highest quality control valves & safety components for hydraulic elevators



Hydraulic Circuit

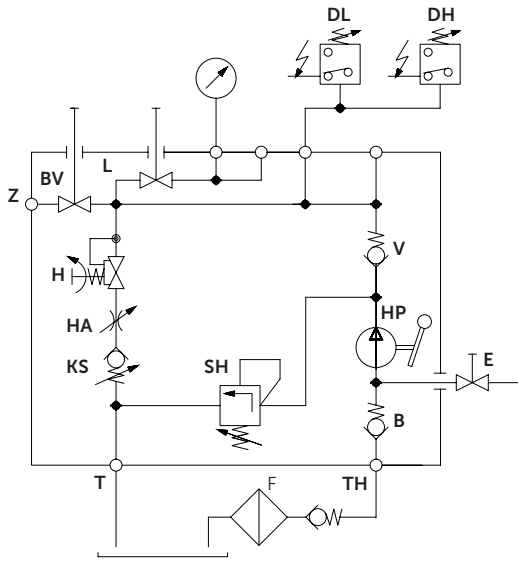

- Z Pressure port
- T Tank port
- TH Suction port
- F Filter
- B Check-Valve (suction)
- V Check-Valve (Pressure line)
- BV Main shut-off valve (built in)
- KS Slack rope valve
- H Manual lowering
- L Shut-off valve for pressure gauge and test port
- HA Manual down speed adjustment
- HP Hand pump
- E Air bleed
- SH Relief valve
- DL Pressure switch 1-10 bar
- DH Pressure switch 1-100 bar

Connections: The output port (1/2") connected to the cylinder line, the oil suction (1/4") and return (1/4") ports to the main tank. Use polyamide oil suction and return pipes with a inside diameter of 6 mm and a outside diameter of 8 mm minimum.

To lower the lift: Open the main shut off valve. Turn the manual lowering anticlockwise. If the speed is too slow adjust the speed adjuster accordingly.

To raise the lift: Open the main shut off valve on the MRL-H unit. To release trapped air inside the unit, open the air-bleed 1/2 or 3/4 turn and pump oil until oil appears at the bleed screw. Tighten the bleed screw and continue pumping to raise the lift.

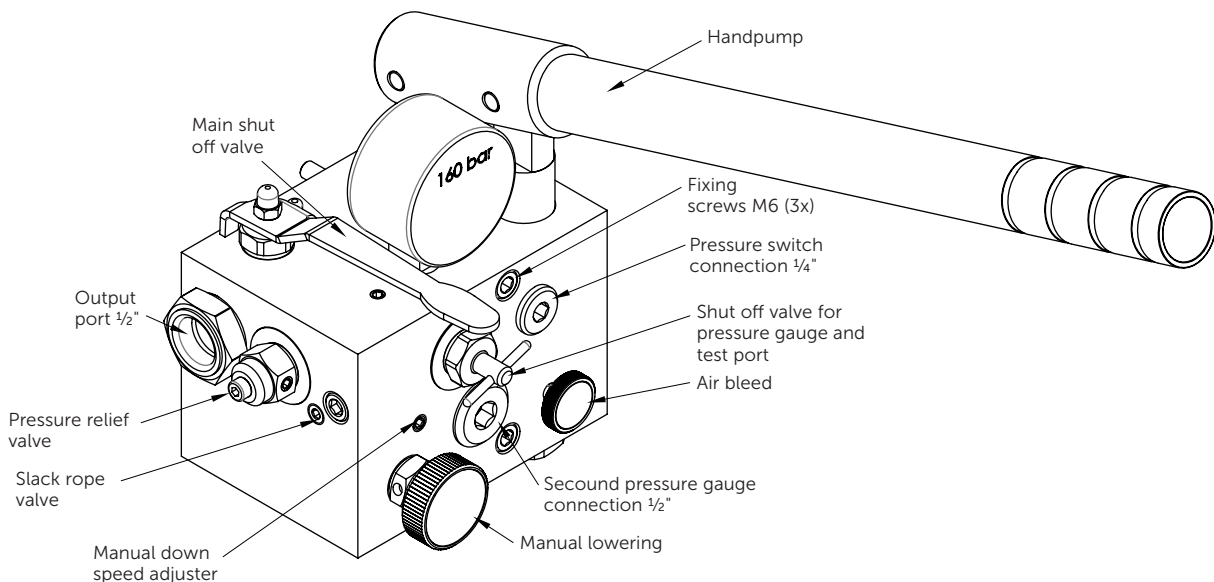

Main shut off valve: Allows pressure line to be kept closed during non-service times.

Slack rope valve: Avoids the ram from being lowered by opening the manual lowering valve below ram pressure/weight.

Manual lowering valve: Descends the car to lower position manually.

Manual lowering speed adjustment: It allows manual lowering speed adjustment away from the main power unit.

Pressure relief valve: By default it is set to 100 bar (adjustable).

Hand pump: Allows servicing people to raise the car to the upper floor.